

# MENEGOTTI TECHNICAL MANUAL

## WHEELBARROW MIXER

### 130 LITERS

#### QR-Code:



Point your cell phone or tablet camera to access the updated version of **Technical Manuals** and **Parts Catalogs** online, or click the link below to access the website.

[www.sites.google.com/view/menegotti-engenharia-docs](http://www.sites.google.com/view/menegotti-engenharia-docs)

#### Attention:

Before operate **Menegotti** equipment, read this **Technical Manual**, itself will inform and instruct the operator about the operation.  
By the way, you avoid possible working accidents and early maintenance on at the equipment.



**MENEGOTTI**<sup>®</sup>  
CONSTRUCTION

## Congratulations on purchasing a Menegotti product!

With the highest quality, designed and built especially to serve you with technology to suit your needs.

This manual was written to provide you with the information and instructions necessary for the use and maintenance of our equipment, as well as to present you with data relating to its technical characteristics.

Before you put your equipment into operation for the first time, carefully read the information contained herein.

The durability of your equipment depends only on the way it is treated during service (operation) and its satisfactory performance is the result of your careful work, carried out regularly.

Menegotti is prepared to offer you all the necessary technical assistance, as well as to meet your needs for spare parts.

Welcome, you are now a part of the great Menegotti "client family".

MENEGOTTI After Sales and  
Technical Assistance departments.

Caution: For best convenience, keep this manual in a appropriate place where it can be consulted when necessary.

## Index

Menegotti Group.....	03
The Product.....	03
Safety Information.....	03
Main Components.....	04
Technical Specifications.....	05
Working and Operating Conditions.....	06
Equipment Cleaning.....	06
Equipment Grounding.....	07
Electric Diagram.....	08
Lubrification.....	09
Leveling adjustment and transportation.....	09
Working Operation.....	10
Assembly procedures.....	11
Exploded view / Spare Parts.....	13
Product Warranty.....	15
Warranty Term.....	15

# Menegotti Group

Menegotti is reference in the development of solutions in machines and tools for the Construction machinery, Handling and Lawn | Garden Segments.

A Brazilian company, present in more than 40 countries, has its headquarters in Jaraguá do Sul, Santa Catarina, units in Brazil and in the United States.

With more than 80th years of history, it is in the fourth generation of consistent and successful family management. National leader in sales of concrete and cement mixers, it stands out in the resale and rental market.

Through its Innovation Program, it fosters creativity and competitiveness, with disruptive actions and partnerships, aimed at continuous professional and business growth.

With an organizational culture that values and encourages its constant professional and personal development, Menegotti is active in sustainable projects, which make its purpose of contribute “to build a better and more sustainable world”, a reality.



## The Product

Product designed for construction works with great performance and low maintenance, with double mixing blades that increase the efficiency. The drum rotation occurs through an electric motor. The discharge system is manual and features transmission mechanisms that facilitate its operation requiring the minimum of human effort.

**Note: With the aim of constantly improving their equipment, Menegotti reserves the right to change the features of the product without notice.**

## Safety Informations

This manual must be completely read before any operation. On it there is useful information about the product, manufacturer, safety, replacement parts, maintenance and conservation. Keep this manual, on a proper place, so it may be consulted when necessary.

- Before using this equipment, carefully, read this manual and follow the Manufacturer's information, such as, how to reduce the risk of accidents in operation.
- It is expressly prohibited to remove or alter any safety device or feature, if it occurs Menegotti will not be held responsible.
- Use the equipment according to the instructions on this manual.
- In case of damage or missing parts, contact MGT North America on our telephone number 770 9107450 for replacement.
- With the machine turned off, conduct a daily inspection of the machine's parts. In case of problems, immediately contact Mengotti's authorized service.
- Maintain a limited area exclusive for working with the equipment, always keeping this place clean, without obstructions and with proper illumination.
- The operator must be trained or qualified to operate this equipment.





- Do not use clothing that is too loose and which might get caught in the machine.
- Always wear gloves, safety gloves and ear protection.
- The engines must be installed by qualified professionals.
- Perform the maintenance recommended on this manual with qualified people and within the correct periods.
- Inspect all electrical, mainly regarding cuts, cable friction and broken connections.
- Never use extensions that are not in good conditions.
- Never use wet extensions or operate in wet environments (i.e. Puddles).
- When cleaning the equipment, never throw water on the motor.
- Whenever performing maintenance on this equipment, disconnect the power cable from its source.
- Avoid contact with hot surfaces.
- Before performing any activity or maintenance, first let the motor cool down.
- Avoid contact with rotating parts.

## Main Components

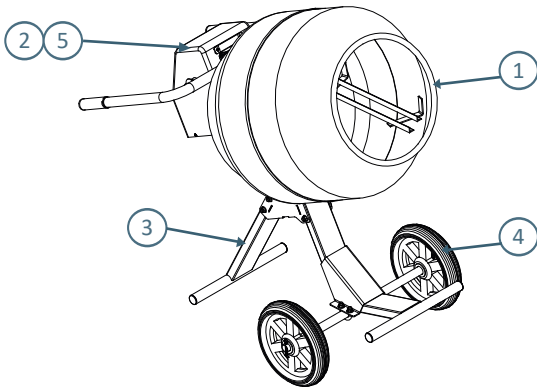

Wheelbarrow Mixer	
1	Drum
2	Motor Box
3	Chassi
4	Wheel
5	Eletrical Safety Kit

# Technical Specifications

WHEELBARROW MIXER	
Drum capacity	5.0 CuFt
Final mixture return	2.3 CuFt
Cycles/hour quantity	15 Cycles
Mix capacity	2.83 CuFt
Hour production	42.4 ft <sup>3</sup> /h
Drum rotation	30 Rpm (60Hz) / 28 Rpm (50Hz)
Eletrical motor	Single-Phase 1/2CV 115/230V UL Certification / CE compliant
Transmission	V-Belt 3L -230
Net weight with motor	135.6 lbs
Carton dimensions (LxWxH)	23 5/8" x 23 5/8" x 24 1/64"

WHEELBARROW MIXER			
Eletrical extension	0 to 20 m	20 to 30 m	Above 30m
Gauge	2.50 mm <sup>2</sup>	4.00 mm <sup>2</sup>	Not recommended

# Working and Operating Conditions

- Attentively read this instruction manual;
- Can be used inside or outside;
- The introduction of any object in the drum, as it is on, can cause serious accidents;
- Any not proper use may consist on a threat to the operator and people nearby physical integrity;
- The operator should be trained or qualified to operate this equipment;
- Keep an exclusive and limited area to work with the equipment, maintaining it cleaning with no obstruction and good illumination;
- Whenever performing maintenance on this equipment, disconnect the power cable from its source.
- Perform the maintenance recommended on this manual with qualified people and within the correct periods.

## Noise Level during Operation

Once the noise level during the Mixer's operation in the drum can reach 95dBA, it is recommended the use of ear protectors during prolonged operation.

## Electrical Characteristics

- Always check if the tension on the power line corresponds to the voltage indicated on the motor's plate identification.
- The maximum length of electrical extensions should not be over 30m. If a bigger extension is needed a technician should be questioned so that the right gauge will be chosen. A bad dimensioned extension may cause fire risks and motor burn.
- Engaging the motor at a different voltage results in damage to the motor;
- Ensure that circuit breakers, electric cables, sockets, and grounding are compatible with that specified in the motor;
- The electrical voltage must not exceed variations of more or less than 10% as it may cause the motor to burn;

## Equipment Cleaning

- The equipment must be unplugged;
- Always clean the equipment after use;
- Clean the drum with water, removing all residue from the blades, internal and external parts of the drum;
- Clean the rack and pinion, removing all abrasive material from the components;
- Take care not to wet the motor.

# Equipment Grounding

- The correct grounding of the concrete mixer is important to reduce the risk of electric shock.
- Make sure that the plug has a pin for grounding , the ground wire must be properly secured to the motor and chassis of the machine as shown in the figures below.
- Use a copper rod of recommended depth and length for 2 meters.
- The ground wire when passing by the on/off switch must not be interrupted or connected to the contacts.
- Do not connect the concrete mixer ground wire directly to the neutral wire.
- The grounding must be done in accordance with the country standards and accompanied by a technically qualified person. In the absence of these standards, it must be carried out according to international standards. Doubts regarding installation contact Menegotti Authorized Service.

**Grounding - Motor**

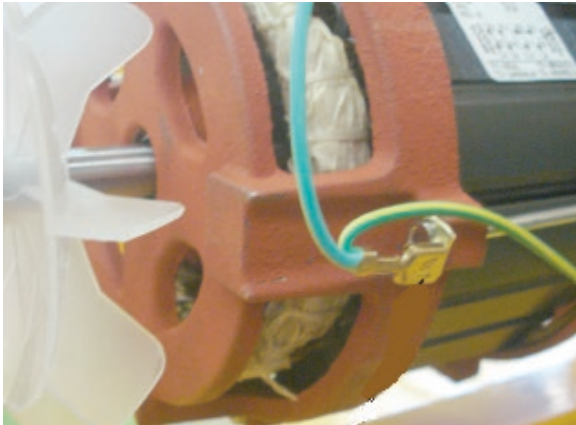

**Grounding - Concrete Mixer**

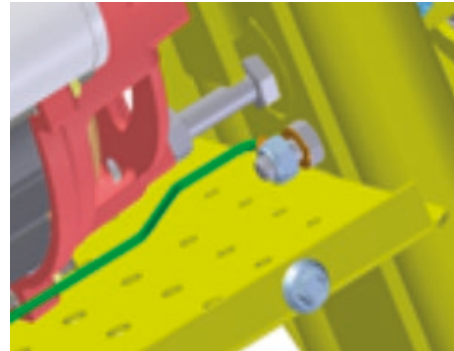

# Electric Diagram

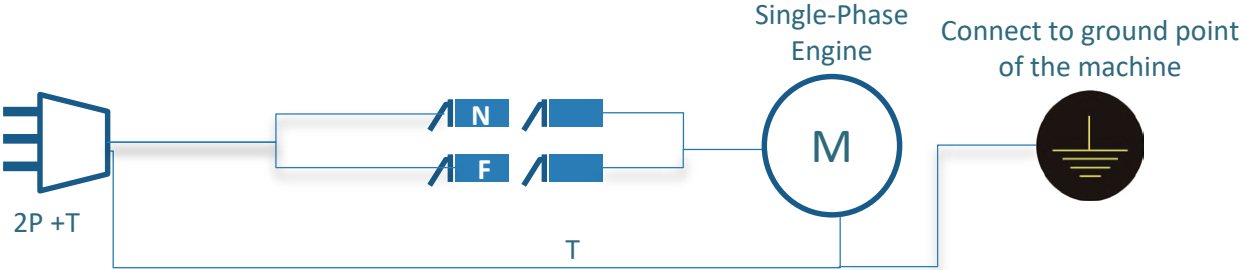



# Lubrication

- Keep machine rotating parts lubricated, such as: pinion, gear ring, bushings, and bearings (with the help of the grease fittings installed in the machine).
- Lubricate the equipment at the beginning of operation, applying grease to all lubrication points.
- Lubrication of the pinion/rack gear assembly is not recommended due to the fact that aggregates such as sand, cement and gravel dust, among others, can adhere to the lubricating agent, causing the mixture to become extremely abrasive, thus resulting in premature wear.

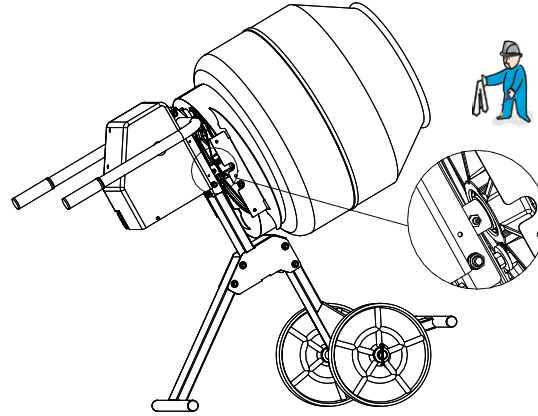

## Recommended Grease

Esso . Beacon 2	⬇
Mobil . Mobilux 3	⬇
Shell . Shell Alvania R2	⬇
Texaco . Multifax EPO	⬇
Castrol . Graxa LM2	⬇
Atlantic . Litholine 2	⬇

# Leveling Adjustment and Transportation

- Do not exceed 5 degrees of inclination relative to ground level.
- The equipment has handlebar to raise a few inches from the ground and transport through the wheels;

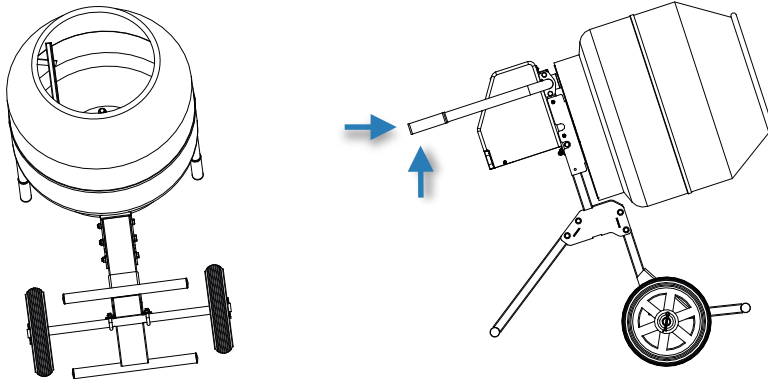

# Working Operation

- Place the concrete mixer on a plain and firm surface in a way to make easier the loading and unloading processes.
- Connect the switch which is in the motor protection box remembering to follow recommendations for the extension.
- Fill the drum and let it mix;
- Once mixing is concluded, tilt the drum until the mixture is discharged;
- During the whole cycle the drum must be rotating.



1. Use a ti for measuring the components.



2. Place the stone inside the drum when the machine is **running**.



3. Add half of the water and mix for **one minute**.



4. Add the cement.



5. Finally add the sand and the rest of water.



6. Let teh concrete mixer rotate for **2.5 minutos** before using the concrete.

# Assembly Procedures

## Check List

Name	Qty.
Central chassis assembly	1
Front chassis assembly	1
Rear chassis assembly	1
Drum	1
Handlebar	2
Wheel axle	1
Wheel	2
Hexagon bolt 3/8" x 4.1/2" UNC	7
Nut 3/8"	11
Flat washer 3/8"	14
Shaft flat washer	2
Counter-pin	2



Apunte la cámara de su teléfono móvil para acceder al vídeo de montaje de la hormigonera o visite el siguiente link.  
<https://www.youtube.com/watch?v=V5fUu1WWsCM>

1 - Assemble the chassis using the washers, nuts, and screws 3/8" supplied with the equipment.

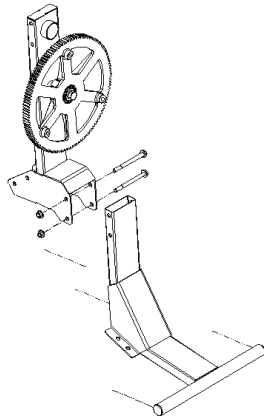

2 - Assemble the rear chassis using washers, nuts and bolts 3/8" supplied with the equipment.

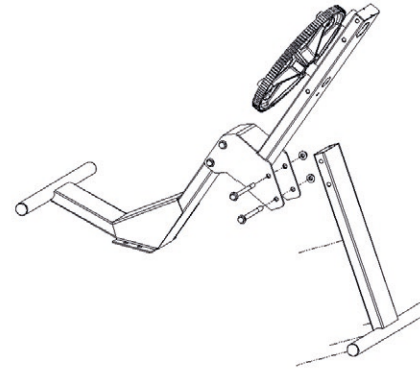

3 - Put the drum down. Place the chassis in the drum so that the gear rack crown engages the screws on the bottom of the drum. Tighten the nuts.

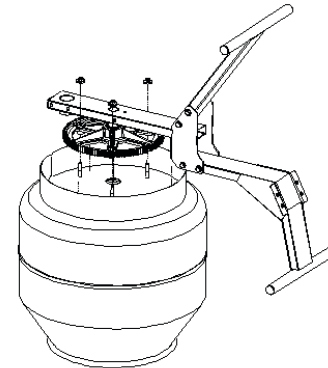

4 - Keep the drum down. Fit the engine housing into the chassis. Check the gear rack and pinion coupling. If there is no coupling, rotate the chassis until it engages the gear rack on the pinion.

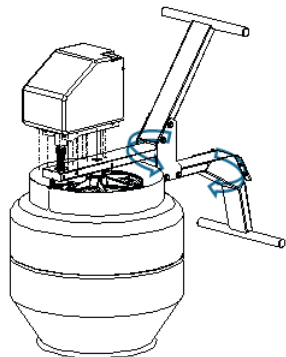

5 - Mount the handlebar to the engine case on the machine chassis.

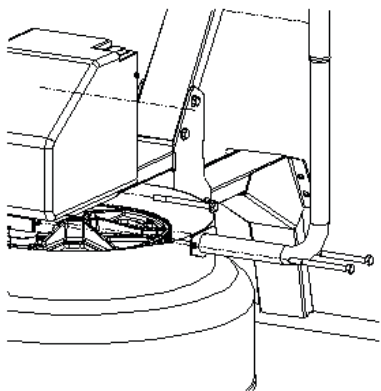

6 - Mount the axle in the chassis fixing with the nuts  $3/8$ ". Mount the wheel on the end of the shaft. Attach the cotter pin to the shaft.

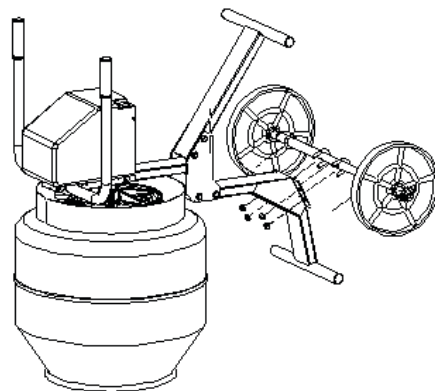

7 - Assembly complete.

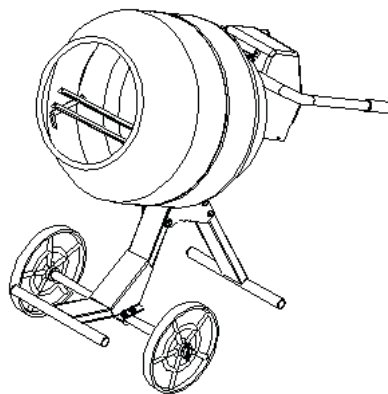

# Exploded View / Spare Parts

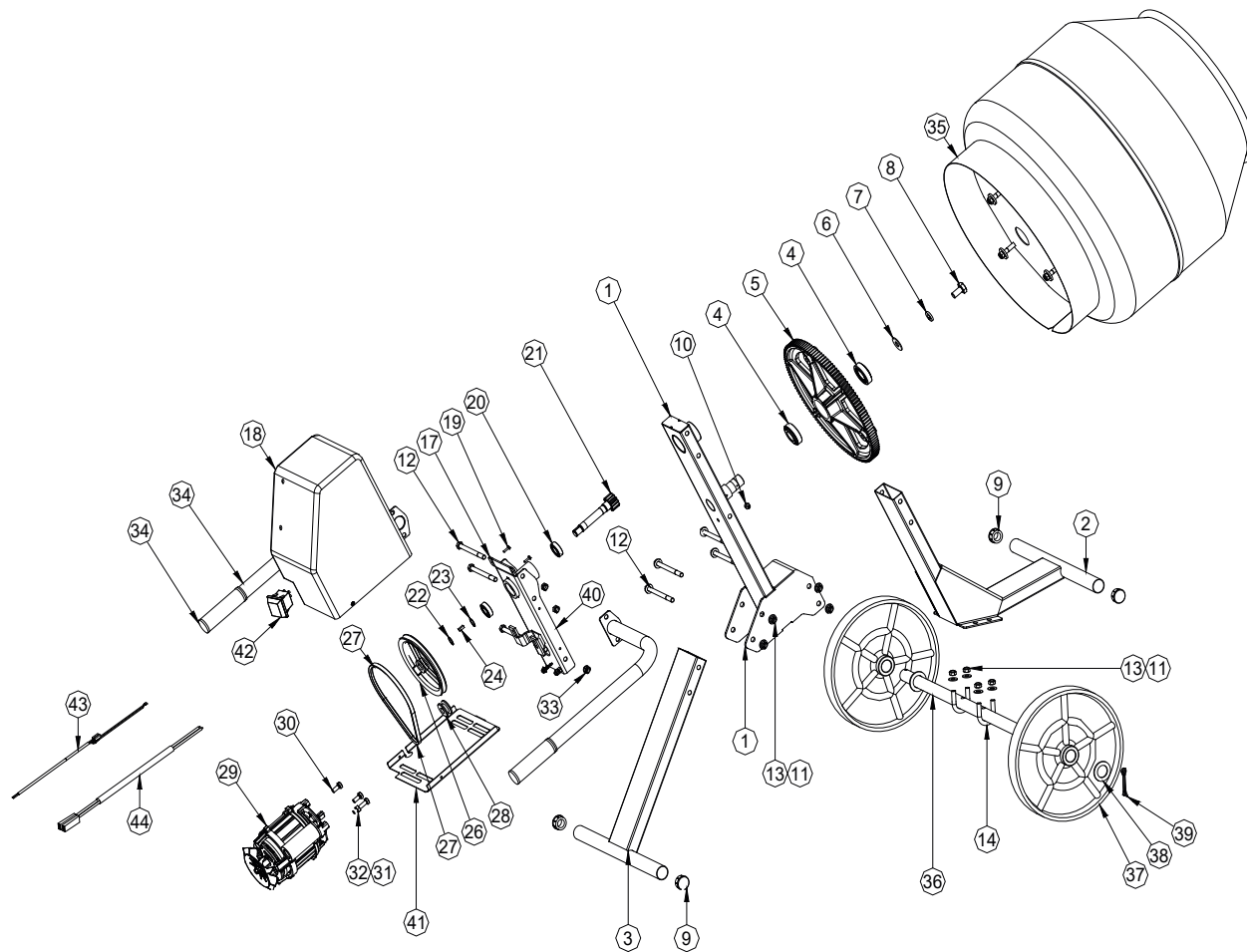

No.	Description	Qty.	Code	Drawing
1	Central chassis assembly	1	32020017	3110163
2	Front chassis assembly	1	32020009	3112154
3	Rear chassis assembly	1	32020003	3112160
4	Bearing 30205	1	22020603	-
5	Gear Rack Z128 / M2,5	1	2124006	-
6	Flat washer ½" UNC	1	21030220	-
7	Spring washer ½" UNC	1	21030106	-
8	Hexagon bolt ½" BSW	1	21010409	-
9	Plug Ø 1. ¼"	4	24110111	-
10	Grease cup 1/8" BSP ZB	1	24040101	-
11	Flat washer 3/8"	14	21030251	-
12	Hexagon bolt 3/8" x 5" UNC RPZB	8	21010137	-
13	Self-locking hexagonal nut 3/8" UNC	11	21021059	-
14	Hook "U"	2	21012483	-
17	Motor housing bracket	1	32040097	3108375
18	Motor box	1	24110108	3108008
19	Self tapping screw 3.5 x 9,5mm	2	21011312	-
20	Bearing 6003 ZZ	2	22020908	-
21	Pinion assembly	1	31020177	-
22	Elastic ring E15	1	21060113	-
23	Elastic ring E17	1	21060115	-

No.	Description	Qty.	Code	Drawing
24	Key	1	21130120	-
25	Switch	1	26100412	-
26	Pulley	1	29110217	-
27	V-belt 3L 230	1	22010360	-
28	Pulley motor	1	31090265	-
29	Single-phase Motor ½"CV 60Hz 127/220V IP00 - UL	1	23014623	-
30	Hexagon bolt M8 x 20 DIN 933	2	21012931	-
31	Hexagon bolt M8 x 40 DIN 933	1	21012813	-
32	Hexagon nut M8 DIN 934	1	21021105	-
33	Flat washer 3/8"	2	21030251	-
34	Handlebar assembly	2	24070171	4122390
35	Drum 130L – 2 blades	1	34600009	2107098
36	Axle assembly	2	31020215	3115047
37	Wheel	2	24110166	3115099
38	Flat washer para roda 28 x 45 x 2,7	2	21030336	-
39	Counter-pin	2	21050106	-
40	Box Support	1	32040097	3108375
41	Box bottom	1	32040228	3108399
42	Single-phase On/Off Switch	1	26100412	-
43	Assembly electric cables without plug	1	26010421	4127011
44	Single-phase cable	1	26010435	4122410

## Product Warranty

The warranty is not transferable under the conditions and within the prescribed period and will be valid from the date of purchase of the equipment, through presentation of the sales invoice to the first end consumer. At the time of delivery of the equipment, the customer must receive the information and technical guidelines for the equipment as per the content of this manual.

Therefore, defects caused by mistreatment, carelessness, negligence, recklessness or malpractice, are not covered by this warranty, nor are any repairs or alterations of any part and/or piece of equipment. Also not covered is any assembly of the parts by any party other than the factory itself or Technical Assistant, application outside the specification, mechanical or electrical overloads or phase failure, use in an environment for which it was not designed, incorrect voltages of frequencies, incorrect lubrication, damage caused by accidents of any kind, such as floods, strong winds, fires, landslides or resulting from transportation.

The removal or alteration of the serial numbers originally placed on the product void the warranty, which must be presented on the sales invoice and the Warranty Certificate for the equipment in question.

The warranty assumed is limited to the repair, spare parts or parts assembly of the set of parts, in which the review is conducted by an Authorized Menegotti Technical Assistant and authorized in advance by the Factory, to double check the existence of the manufacturing defect. This repair or exchange will be made by an Authorized Technical Assistant, with the buyer bearing the risks or costs of transportation to and from the Technical Assistant, with the labor and replaced parts being free, under the terms of this warranty.

This supersedes any other warranty, express or implied as well as any and all liability or responsibility of our company concerning the above product.

**MENEGOTTI After Sales and Technical Assistance departments.**

## Warranty Term

By the present CERTIFICATE provided from original purchaser, Menegotti guarantees this product against manufacturing defects, for a period of 12 (twelve) months counted from the invoice issue date of the first final consumer. The components of daily use such as: bearings, clutch disc, gears, tires, brake shoes, etc. are not included in the warranty.

This warranty includes spare parts and repair against manufacturing defects duly verified by the factory or Authorized Technical Assistance. The warranty for this product will be void if it suffers damage caused by accidents, natural events, application outside the specification, or in the case of alterations or repairs by a person or workshop not authorized by Menegotti. The product freight charges, including the technical assistant or factory, are borne by the consumer.

If the equipment is purchased with the electric engine warranty covers defects arising from the internal engine manufacture. Not covered by warranty defects of: broken or crushed shell due to carelessness in transporting/or storage, energization of the motor coupling or out specification defects, general misuse and /or incorrect installation, overcharging due to lack or excess of phase and use of voltage out of the specification.

Aware of this term,

**Customer:** \_\_\_\_\_  
**Model:** \_\_\_\_\_ **Serial Number:** \_\_\_\_\_  
**City:** \_\_\_\_\_ **Date:** \_\_\_\_\_

\_\_\_\_\_  
*Customer*

\_\_\_\_\_  
*Menegotti Authorized Service*

# Menegotti GROUP

Solid values, *sustainable future.*

**MENEGOTTI**  
HANDLING

**MENEGOTTI**  
CONSTRUCTION

**MENEGOTTI**  
HOUSE & GARDEN



**Unit • Unidat Menmaq**

Erwino Menegotti, 381 - Água Verde  
Jaraguá do Sul - SC - 89254-000



**Unit • Unidat Mentec**

José Theodoro Ribeiro, 2399 - Ilha da Figueira  
Jaraguá do Sul - SC - 89258-468



**Unit • Unidat Menfer**

Saudade, 186 - Seminário  
Corupá - SC - 89278-000



**Unit • Unidat MNA**

248 E Crogan St STE 301 - Lawrenceville - GA  
30046 - United States

[grupomenegotti.com](http://grupomenegotti.com)