

MENEGOTTI TECHNICAL MANUAL REVERSIBLE PLATE COMPACTOR MPR 2500

QR-Code:



Point your cell phone or tablet camera to access the updated version of **Technical Manuals** and **Parts Catalogs** online, or click the link below to access the website.

www.sites.google.com/view/menegotti-engenharia-docs

Attention:

Before operate **Menegotti** equipment, read this **Technical Manual**, itself will inform and instruct the operator about the operation.
By the way, you avoid possible working accidents and early maintenance on at the equipment.



Illustrative image.

MENEGOTTI

NORTH AMERICA 

Congratulations, you have just purchased a Menegotti product!

With the highest quality, projected and built especially to serve your needs.

This manual was elaborated to provides the informations and key instructions to use and mantain our product, in addition presents their technical characteristics.

Before use the product for the first time, read and pay attention at the informations in this manual.

The product durability only depends the way you treat it in service (operation) and the satisfactory working is consequence of yours regular work carefully.

Menegotti is prepared to offer you all technical assistance, and attend all your needs about replacement parts.

Welcome, you are part of the huge Menegotti “customers family”.

After sales Department
and Technical Assistance MENEGOTTI.

Attention: For better comodity, store and keep this manual in a properly spot so it can be easily checked.

Index

Menegotti Group.....	03
The Product	03
General Use and Care	03
General Care.....	04
Technical Info.....	04
General Vision of the Equipment	05
Starting the Equipment	06
Operating the Equipment	08
Turning Off the Equipment	09
Equipment Transport.....	10
Preventive Maintenance	10
Maintenance Chart.....	14
Quantities Chart	14
Product Warranty.....	15
Warranty Term	15

Menegotti Group

Menegotti is reference in the development of solutions in machines and tools for the Construction machinery, Handling and Lawn | Garden Segments.

A Brazilian company, present in more than 40 countries, has its headquarters in Jaraguá do Sul, Santa Catarina, units in Brazil and in the United States.

With more than 80th years of history, it is in the fourth generation of consistent and successful family management.

National leader in sales of concrete and cement mixers, it stands out in the resale and rental market.

Through its Innovation Program, it fosters creativity and competitiveness, with disruptive actions and partnerships, aimed at continuous professional and business growth.

With an organizational culture that values and encourages its constant professional and personal development, Menegotti is active in sustainable projects, which make its purpose of contribute “to build a better and more sustainable world”, a reality.



The Product

The Vibratory Reversible Plate MPR 2500 is a compaction machine, able to work quickly by applying consecutive impacts to the ground surface to level the uneven ground surface, uniformizing it so that the space between the particles shrinks, and to increase the dry density of the soil that has its moisture removed by the compaction process. The MPR 2500 is intended exclusively for the compaction of: Sand, Clay, Gravel, Asphalt, Wet concrete, Interlocking floors, to avoid sedimentation and provide a firm and solid foundation.

General Use and Care

The MPR 2500 - Reversible Plate Compactor is intended exclusively for the compaction of:

- Sand, clay and gravel;
- Side walk and floor pavers;
- Basic Sanitation Sewage Lines, Bridge decks;
- Landscaping and retaining walls;
- Asphalt repair;
- Small and middle size construction;
- Use in road construction and structural engineering.

General Care

- The compacting plate shall be inspected at least once per shift for verification of visible damage. In the event of their existence, immediately stop the operation and inform the person responsible;
- Perform PREVENTIVE maintenance according to the specifications in this instruction manual. This action will increase the life of the machine and ensure your warranty right;
- Do not break the seal and change the engine speed, this generates excessive wear on the motor, base and eccentric of this machine;
- Do not tilt the machine to the side of the engine fuel filter, as the fuel eventually moves towards the air filter damaging it;
- Do not use the machine on “super” compacted terrain, such as ALREADY DRY ASPHALT or too compacted floors;
- The operator must be of legal age, be trained to operate this equipment and always use OBLIGATORY PROTECTIVE EQUIPMENT.

OBLIGATORY PROTECTIVE EQUIPMENT



Technical Info

Info	World Metric		US Metric	
Weight	kg	136	Lb	299,8
Base Plate Dimensions	Width x Length (cm)	50 x 75	Width x Length (cm)	19,7 x 29,5
Fuel Type/Consumption	Petrol (Liters)	1,5	Petrol (Gallons)	0,39
Fuel Tank Capacity	Liters	3,1	Gallons	0,82
Engine Brand	Honda GX 200			
Power	hp	6,5	kW	4,3
Forward Speed	Meters per Minute	22	Feet per minute	72
Force of Impact	kN	25	kN	25
Frequency	Hz	87	Hz	87
Compaction Depth	Centimeter	Up to 30	Inches	Up to 11,81
Surface Compaction Capacity	m ² /h	700	Square Feet per Hour	7534,7

General Vision of the Equipment



Number	Part
01	Reversion Gear Box
02	Cable Guide Bar
03	Cable Height Adjust
04	Engine
05	Eccentric Gear Box
06	Base Plate
07	Console
08	Protective Cage
09	Uplifting Shoulder Strap
10	Guide Bar Clip
11	Accelerator
12	Reversion Guide Bar

Starting the Equipment

1.1. SET THE POWER BUTTON

- Turn from "OFF" to the "ON" position.



1.2. OPEN THE FUEL TAP

- Move the fuel tap lever to the indicated position on the image at the side.

1.3. SET THE CHOKER

- Move the choker lever to the indicated position on the image at the side.



1.4. SET THE ACCELERATOR

- Move the accelerator lever to the indicated position (minimum or ¼) on the image below.



ACCELERATOR MINIMUM OR
1/4 FORWARD

1.5. PULL THE RECOIL STARTER

- Slowly pull the recoil starter lever until you notice a resistance and then pull it a little harder and quickly for about 5 times. This will make the fuel flow to the carburetor;



CHOKER

OPEN



AFTER
ENGINE START

1.6. AFTER THE ENGINE STARTS (COLD START)

- Let the engine heat up for a couple minutes;
- Set the choker lever to the “open” position;

1.7. INSTRUCTIONS FOR DAILY OPERATIONS

- If the engine is still warm, you don't need to be using the choker over the following starts during your daily operations;
- When lifting or transporting the machine, always close the fuel tap. This procedure will help on the cleaning and lifetime of your carburetor;
- When not using the machine for more than 3 days, always make the procedure of "shut off" by engine stalling, this will prevent the carburetor to get dirty with gasoline impurities.

***REMINDER! The operator must be of legal age, be trained to operate this equipment and always use mandatory personal protective equipment (PPE).**

Operating The Equipment

- In order to start any soil compaction move the accelerator lever to the MAXIMUM position;
- Always guide the machine holding the cable guide bar.

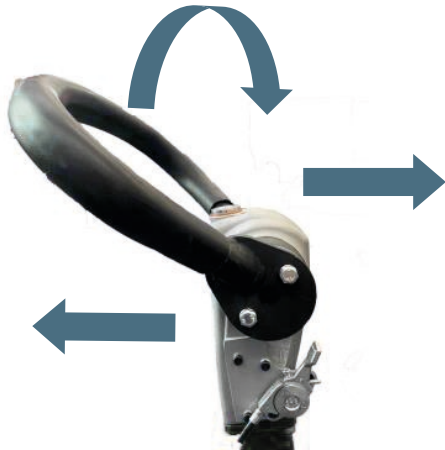

2.1. REVERSIBLE CABLE GUIDE BAR

- If you want to compact forward push the reversion guide bar to the forward position;
- If you want to compact towards the back position pull the the reversion guide bar to the backward position.

2.2. ADDITIONAL INSTRUCTIONS

- Do not force the machine let it move automatically according to the position you put the REVERSIBLE GUIDE BAR;
- Avoid operating close to critical terrain positions;
- The reversible system enables you to compact soils in both ways , forward and backward;
- Always perform compaction with the accelerator lever at maximum speed this will make you achieve the best soil compaction performance.

Turning Off the Equipment

3.1. TURNING OFF THE EQUIPMENT | ENGINE STALLING METHOD

- Move the throttle lever to the minimum speed;
- Move the fuel tap to the left to close;
- Wait for the engine of the machine to shut down by itself due to lack of fuel;
- SHUTDOWN BY engine stalling due to lack of fuel.



FLOATING CARBURETOR

- This machine is equipped with floating carburetor.

3.2.FLOATING CARBURETOR | CLEANING SYSTEM

- Doing the “engine stalling” shutting down method regularly will maintain the carburetor clean and with longer life.

3.3. TURNING OFF THE MACHINE | QUICK AND DAILY METHOD

- Turn the POWER BUTTON from “ON” to “OFF”.

TURN OFF
 **POWER**
BUTTON
ENGINE



Equipment Transport

- Attach the Guide Bar to the “Guide Bar Clip”;
- Lift the machine through the uplifting shoulder strap.



Preventive Maintenance

5.1. ENGINE OIL LEVEL

- Remove the engine oil level indicator and check the oil level.
- The oil level must be between the minimum and maximum MARKING.



5.2. CHANGING ENGINE OIL

- Place a container on the back edge of the engine console;
- Remove the oil drainage bolt;
- Drain the oil while the engine is hot (just turned off) to ensure fast and complete drainage;
- Use a jar to collect the old oil - See the image at the side.

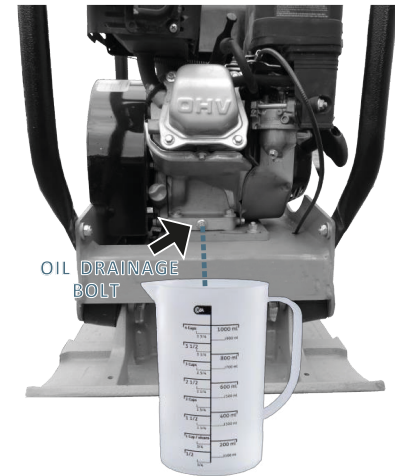

5.3.1 V-BELT REPLACEMENT

- Remove the V-BELT protection;
- Unscrew the console/base plate (rubber shock absorbers) thus releasing the V-BELT tension;
- Take off the OUTWORN V-Belt by rolling the clutch and sliding the V-BELT out from the clutch;
- Place the new V-belt in two steps: First on the outer edge clutch and then on the pulley, as shown below.



5.3.2 V-BELT REPLACEMENT SECOND PART | LEVELLING CONSOLE AND V-BELT TENSION

- The belt tension is regulated by the console height (RUBBER SHOCK ABSORBERS) fixing screws;
- Use a bubble level and a wrench to screw the RUBBER SHOCK ABSORBERS BOLTS and tight the V-BELT and letting the console aligned at rear back edges and consoles sides;
- If you REPLACE THE ENGINE, you should be aware to align the V-BELT by when screwing the engine /console FIXING BOLTS.

***Always use the V-Belt indicated in the “QUANTITIES CHART” of this manual.**

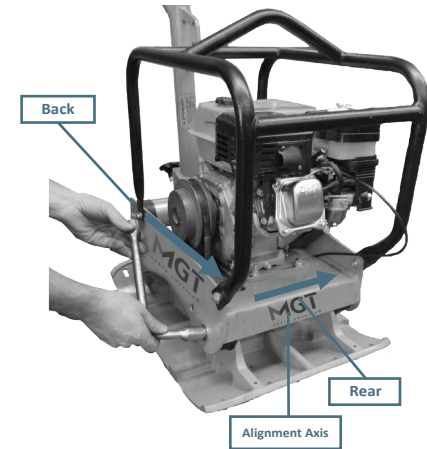

5.4. REVERSION GEAR BOX | OIL CHANGE

- Always keep the oil level at maximum;
- Oil level viewer is at the image in the side;

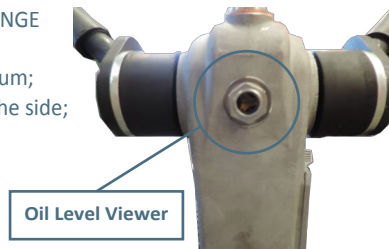

5.4.1. OIL REPLACEMENT

- Remove the Oil Change Screw from the reversion gear box;
- Insert a 10mm silicone tube, SUCTION and allow to drain into a gravity container;
- After you drained all the oil replace it with new oil.
- For Quantities and period of Exchange go to the QUANTITIES/MAINTENANCE CHART.

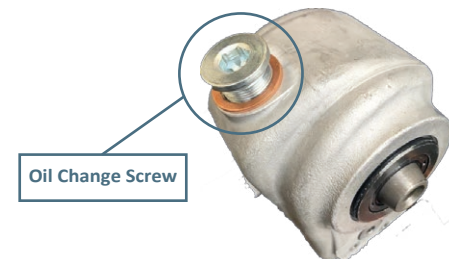

5.5 ECCENTRIC GEAR BOX OIL EXCHANGE

- Due to the complexity in performing the oil change of the eccentric box, we recommend that this operation should be carried out by an authorized technical assistance;
- Contact us to find an authorized technical assistance.

5.6. AIR FILTER REVIEW

- Loosen the air filter cover;
- Remove the filter from the air box and clean according to the specifications of the engine manufacturer;



IMAGE 1: AIR FILTER SET

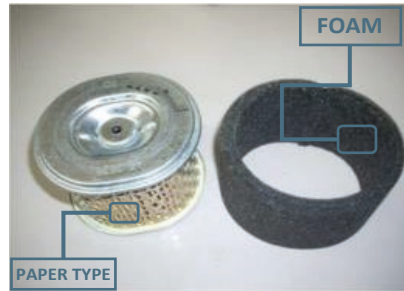

IMAGE 2: AIR FILTER ELEMENTS

5.6.1. STANDARD PROCEDURE | AIR FILTER ELEMENT CLEANING

- AIR FILTER FOAM: Remove the air filter “FOAM” element. Wash it with soap and water. Replace it if it is too damaged;
- PAPER TYPE: insert a compressed air jet from THE INSIDE OUT.

***In case of damage or excess impurities, replace the paper filter element by a new one.**

Maintenance Table

MAINTENANCE PERIOD	PART	TASK
After the first 20 hours of operation	Engine	<ul style="list-style-type: none"> • Change the engine oil • Tighten all accessible screws and nuts
After every 8 hours of operation/Daily	Air Filter	<ul style="list-style-type: none"> • Clean air filter and observe possible damage. Replace it if necessary
After every 40 hours of operation/Every six months	Engine	<ul style="list-style-type: none"> • Change the engine oil • Replace the fuel filter • Replace the oil filter
After every 300 hours of operation/Annually	Eccentric Gear Box	<ul style="list-style-type: none"> • Exchange the oil
After 12 months of use	Reversion Gear Box	<ul style="list-style-type: none"> • Exchange the oil
	V-Belt	<ul style="list-style-type: none"> • V-Belt change

Quantities Chart

PART	TYPE	QUANTITY
Engine	Oil Type SAE 20W50	GX 200 0,6 Liters (20 US Oz)
Fuel Tank	Petrol	GX 200 3,1 Liters (0,82 US Gallons)
Eccentric Box	Oil Type GT Oil Gear GL-5 SAE 90	750 ml
Reversion Gear Box	Hydraulic Oil nº YPF PEX 68	350 ml
V-Belt	PROFILE "V" Type A 37 (Internal Circumference: 940 mm)	1

Product Warranty

The conditions and terms of this warranty are non transferable and go into effect on the date of purchase of this equipment, proven by presentation of the sales invoice issued to the first end user. At the time of delivery of the equipment, the customer must be provided with the information and technical orientations according to the contents of this manual.

Not, however, included in this warranty are defects arising from improper use, negligence, imprudence or malpractice, nor are repairs or alterations to any part and/or component of the equipment. Also not included are: the assembly of any sets of parts by technicians not from the Factory itself or from an Authorized Technical Assistant, application other than which it was specified, mechanical or electrical overloading as well as lack of phase, use in environments for which it was not designed, incorrect voltages and frequencies, incorrect lubrication, damage caused by accidents of any nature, such as floods, gales, fire, landslides or due to transportation.

Removal or any alteration to the series numbers originally placed on the product will render the warranty null, where the Sales invoice and Warranty Certificate must be presented in relation to the equipment in question.

This warranty is limited to the repair, replacement of parts or assembly of parts in which, through examination by a Menegotti Authorized Technical Assistant with prior authorization from the Factory, any manufacturing defect will be verified. This repair or replacement will be performed by the authorized Technical Assistant, where the purchaser will be responsible for risks and expenses arising from transport to and from the authorized Technical Assistant, and where labor and parts will not be charged according to the terms of this warranty.

This warranty replaces any other warranty, implicit or explicit, as well as all any obligation or responsibility on the part of our company in relation to the above mentioned product.

MENEGOTTI Post Sales Department and Technical Assistance.

Warranty Term

By the present CERTIFICATE provided from original purchaser, Menegotti guarantees this product against manufacturing defects, for a period of 12 (twelve) months, being: the first 3 (three) months of legal guarantee, and the last 9 (nine) months a special warranty guaranteed by Menegotti, counted from the invoice issue date of the first final consumer. The components of daily use such as: bearings, clutch disc, gears, tires, brake shoes, etc. are not included in the warranty.

This warranty includes spare parts and repair against manufacturing defects duly verified by the factory or Authorized Technical Assistance. The warranty for this product will be void if it suffers damage caused by accidents, natural events, application outside the specification, or in the case of alterations or repairs by a person or workshop not authorized by Menegotti. The product freight charges, including the technical assistant or factory, are borne by the consumer. Menegotti has a wide network of Technical Assistants throughout the country.

If the equipment is purchased with the electric engine warranty covers defects arising from the internal engine manufacture. Not covered by warranty defects of: broken or crushed shell due to carelessness in transporting/or storage, energization of the motor coupling or out specification defects, general misuse and /or incorrect installation, overcharging due to lack or excess of phase and use of voltage out of the specification.

Aware of this term,

Customer: _____
Model: _____ **Serial Number:** _____
City: _____ **Date:** _____

Customer

Menegotti Authorized Service

Menegotti GROUP

Solid values, **sustainable future.**

MENEGOTTI[®]
HANDLING

MENEGOTTI[®]
CONSTRUCTION

MENEGOTTI[®]
HOUSE & GARDEN



Unit • Unidad Menmaq

Erwino Menegotti, 381 - Água Verde
Jaraguá do Sul - SC - 89254-000



Unit • Unidad Mentec

José Theodoro Ribeiro, 2399 - Ilha da Figueira
Jaraguá do Sul - SC - 89258-468



Unit • Unidad Menfer

Saudade, 186 - Seminário
Corupá - SC - 89278-000

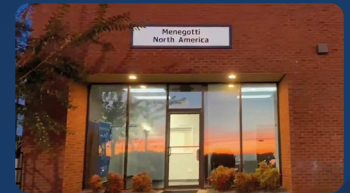

Unit • Unidad MNA

248 E Crogan St STE 301 - Lawrenceville - GA
30046 - United States

grupomenegotti.com